



# HASTINGS DATA LOGGERS

*Australia's portable data logging specialists*

## Datamate Datalogger Shelter

The HDL Datamate datalogger shelter protects temperature and humidity loggers from direct sunlight, wind, and rain, allowing measurement of true air conditions. It can be mounted on a star post (or similar) or hung from above.

Designed and manufactured in Australia for Australian conditions, the shelter will withstand constant exposure to the elements for several years.

Please carefully check the contents before assembly to ensure all components have been received.

### Contents:

1 Top	(Disk A)
1 Insulated Ring	(Disk B)
4 Open Rings	(Disk C)
1 Open Ring with two 3mm mounting holes	(Disk D)
1 Base	(Disk E)
1 Mounting Bracket	
4 Stainless Steel self-tapping screws	
3 Stainless Steel threaded rods with dome nuts	
3 Stainless Steel wing nuts	
1 Zinc-plated U-bolt	

### Assembly Instructions:

1. Secure the mounting bracket to the bottom of the base (disk E) with the 4 stainless steel self-tappers.
2. Locate 3 threaded rods through disk A (top of shelter).
3. Turn disk A over with threads pointing upwards.
4. Place disk B over the studs.
5. Place 4 x disk C over studs.
6. Align the mounting holes in disk D with the mounting hole in disk A (Used for tying down if hung from above).
7. Screw studs (finger tight) into disk D. Then apply half a turn with a spanner (do not over-tighten).
8. Place Datalogger in mountings of disk E.
9. Secure base (disk E) to Star post or similar with U bolt.
10. Place the top section of the shelter over the base with the threaded rods located through the holes in the base.
11. Secure the top section to the base with the wing nuts.

### Access to dataloggers:

Simply remove the wing nuts and lift the top section of the shelter from the base. The loggers can then be interrogated and placed back in position. The top section of the shelter is then positioned back over the base and secured with the wing nuts.

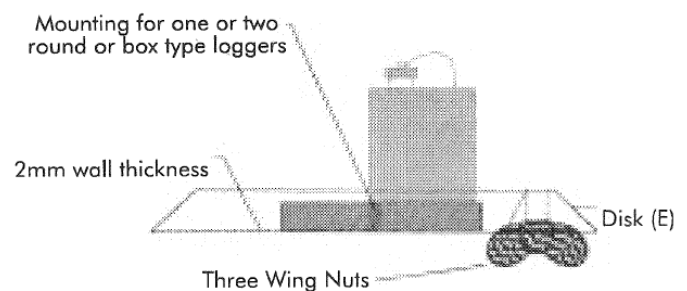
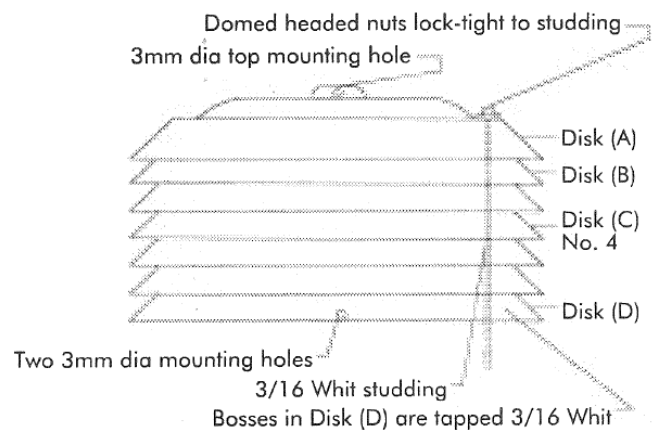

Unit 10, 10 Bellbowrie Street Port Macquarie NSW 2444, P.O Box 5112 Port Macquarie NSW 2444

Phone 02 6581 3900 Fax 02 6581 3988 ABN: 84068411549

Email: [sales@hdl.com.au](mailto:sales@hdl.com.au) web: [www.hdl.com.au](http://www.hdl.com.au)